

SURREALISM AND WOMEN ARTISTS

SURREALISM, A LITERARY AND ARTISTIC MOVEMENT THAT began in Paris in 1924, was soon transported to Mexico and the United States, where it had a lasting impact on women artists. Surrealists wanted to bypass the thinking mind and activate unconscious feelings, which would enable them to render images of suppressed fears and emotions in their art. Surrealist works of art often are characterized by a dreamlike perception of space, incongruous juxtapositions of subject matter, and fantastic imagery.

The story of surrealism in the United States began with two women artists, Lee Miller and Rosa Rolanda, who came from opposite sides of the country (New York and California, respectively) and found themselves in 1920s Paris posing for painter and photographer Man Ray (United States, 1890–1976). Both women were determined to create their own identities, and they used innovative techniques in photography to begin an exploration of their worlds and themselves. While some surrealist women worked in France, it was not necessary to live or travel abroad to encounter surrealism; for example, Helen Lundeberg spent her entire early career in Southern California, only visiting New York once.

Whether women artists went abroad or worked domestically, surrealism offered them a freedom found in no previous aesthetic. It enabled women in Mexico and the United States to construct new identities that demonstrated their independence and imagination. By the end of the 1930s, Mexico City, New York, San Francisco, Los Angeles, and to a lesser extent Chicago had become important centers for surrealism. However, the story goes beyond specific urban centers, for it involves a remarkable network of friends and associates in several countries.

Unwittingly, surrealism became the source of two currents of creativity: the imagined, which arose

from intellect and was created primarily by men, and the intuited, which arose from experience and was generated mostly by women. The women's art visualized the female psyche as it had not been seen before, and it opened a new dialogue that gradually transformed the relationship between the genders.

These curriculum materials explore the works of four twentieth-century women artists who represent different aspects of surrealism. The works and artists examined illustrate the ways in which surrealism became a diverse and viable visual vocabulary: Frida Kahlo's continual reinvention of persona, Helen Lundeberg's classical representations, Lola Alvarez Bravo's concern for social justice, and Rosa Rolanda's lesser-known autobiographical and experimental work.

Art as Identity

Although the male surrealists in Paris during the 1920s explored the unconscious through dreams and induced trances, their paintings did not necessarily express individual personal experiences. In this, the women differed substantially from their male counterparts, as their art often reflected personal traumas and nightmares. For them, surrealism became a means of gaining self-awareness, exploring their inner thoughts and feelings, dealing with their experiences, and locating or constructing their true identities.

The themes that dominated the work of women surrealists in Mexico and the United States reflected the artists' past experiences, present-day situations, fears, hopes, and desires. The feminine dialogue between the self and the other was distinct from male surrealists' outward projection of their desires. Women transformed the female body to a site of resistance, psychic power, and creative energy. They also helped set the stage for the feminist movement by creating art that challenged established social institutions and gender boundaries.

The Role of Portraiture in Surrealism

Because much of the art of women surrealists was self-referential in nature, portraiture was an ideal vehicle for exploring identity. Within that genre, self-portraits were essential, whether they were presented as straightforward depictions, autobiographical or fabricated stories, or symbolic still lifes.

Since the time of the Egyptians, portraits have served as documents that record an individual's likeness at a particular moment in time. While traditional portraiture provided information and clues about the sitter's characteristics, interests, social status, or history, women artists in the surrealist movement approached portraits and self-portraits in a nontraditional manner, as exemplified by the works of Frida Kahlo, Rosa Rolanda, and Helen Lundeberg.

Unlike the male surrealists, women artists and writers sought to reconstruct their identities through the strategy of self-representation, exploring the varieties of self-portraits through painting and through autobiographical narrative. They produced an astonishing number of portraits and self-portraits. According to Museo de Arte Moderno curator Tere Arcq, "This genre became a form of representation 'in which the artist is both subject and object and conceives of how she looks in the sense of how she sees rather than how she appears.'"¹

- Surrealist artists experimented with a variety of visual media such as painting, photography, photogram, collage, and montage. Study the artworks in this curriculum and think about the messages they convey. How does the artist's choice of medium help express this message? Write this message in your own words using a literary medium such as narrative or poetry.

The Role of Photography in Surrealism

The surrealists exploited the ambiguous relationships between photography as document, as technical experiment, and as product of the imagination, and they did so more surely and with greater effect than any other group of artists in the twentieth century.

Processes such as the photogram (cameraless photographs), which could be linked directly to surrealist automatism or automatic writing, had a history independent of the movement. There is no clear demarcation within the huge repertoire of photographic practices between the works of the surrealists and those of other artists, and often it is the context that situates a photograph specifically within a surrealist frame.

Photomontage, or photocollage, had become by the 1930s a relatively widespread technique that was practiced by artists across numerous visual and social movements. It became a popular medium at the end of World War I, when it was used more or less simultaneously by Russian and German modernists. Artists selected the images to be included in the photomontage, and through the artistic device of juxtaposition expressed satire, political views, private fantasies, or dreams of a utopian, technological, and egalitarian future. Practices varied enormously: artists might simply paste a face or other fragment onto an existing image, cut up and recombine photographs in both positive and negative forms, cannibalize newspapers, or add captions and scraps of text. While the surrealists combined unrelated images and fragments to challenge preconceived notions, the technique's capacity to convey a message also captivated the worlds of politics and advertising.

- Consider the ways in which artists, social documentarians such as journalists and photojournalists, and advertisers record contemporary life. Collect a variety of sources, such as magazines, newspapers, and your own photographs. Cut images, headlines, phrases, and even fine print from these sources that catch your eye. Think about how the artistic device of juxtaposition, or placing incongruous imagery in visual conversation, can help convey a message. Arrange the pictures and text by overlapping, underlapping, or placing them side by side to create a composition.

Drawing Photogram, c. LATE 1920S

ROSA ROLANDA (UNITED STATES, 1895–1970, ACTIVE MEXICO)

IN THIS BLACK-AND-WHITE IMAGE, WE SEE THE NUDE FIGURE of a young woman covered by an inverted glass, which becomes her garment. The translucent glass allows the curves of her figure to be seen, but it still provides a modest covering. The shape of the glass is reminiscent of dress styles of the mid-1800s, with a wide hooped skirt and narrow waistline.

The figure's stylized face can be recognized as that of the artist, Rosa Rolanda, from the self-portraits she produced throughout her artistic career. In fact, her painted self-portraits from 1945 and 1952 depict the same somber persona. The simple style of her features is similar to those found on folkloric images of the sun reproduced in ceramics, wood, and textiles. Here, crowned by the sun, she is surrounded by shells, a deer, and a ruler. We can read this image as if it were a page from an ancient Mesoamerican codex (an illustrated book), telling the history of a great civilization, with Rolanda posed in ceremonial garb with glyphs representing the natural world—fire (sun), water (shells), earth (deer), and a device for measuring distance.

These images have historical or symbolic meaning in pre-conquest Mesoamerica. The deer appeared consistently in Mesoamerican creation myths, most frequently as a metaphor for the sun courting the moon. In ancient Mexico and Guatemala, shells were imported inland from the coast, where they were used by nobles for trade and tribute. Conch shells were also associated with the Aztec rain god Tlaloc. Instead of an Aztec calendar measuring time, there is a ruler, which measures distance. This is an appropriate symbol for Rolanda, who was a young dancer from Azusa, California, and who by age thirty-one had been to New York, Europe, and Mexico. Conversely, the image in the photogram is standing stationary, which is out of character for a dancer.

To make a photogram, objects are placed onto photosensitive paper; direct sunlight develops the imagery. The earliest examples of this experimental technique can be dated to the 1830s and the work of inventor William Henry Fox Talbot (England, 1800–1877). During the 1920s and afterward it was used by Man Ray, whom Rolanda met in Paris.

Rolanda was introduced to the photogram technique—that is, cameraless photographs—in the 1920s, either during her tour as a dancer with the Ziegfeld Follies in 1923, when Man Ray photographed her, or after she and her husband, the artist Miguel Covarrubias (Mexico, 1904–1957), returned to Paris in September, 1926. Man Ray was not the only artist who used Rolanda as a model. The artists and writers who associated with Covarrubias at that time, including photographer Edward Weston (United States, 1886–1958), were actively exploring as well as creating Mexican cultural identity. While Weston was living in Mexico (1923–26), Rolanda posed for him wearing traditional costumes such as a Maya *huipil* and a Mexican Tehuana dress.

- **Image and Identity:** Think about all the ways you can produce a self-portrait—through drawing, painting, photography, even writing. Surrealist artists used a combination of these media to build on a long tradition of portraiture in art. A portrait can not only capture a person's likeness but also his or her personality and interests. Make a list of words that describe your personality, such as your favorite colors, places, and things to do. Include many of these characteristics in a self-portrait that tells us about you. Consider the setting, what you will hold, and what you will wear. Supplement the composition with symbolism and imagery that is important to your heritage or to your family's background or country of origin.

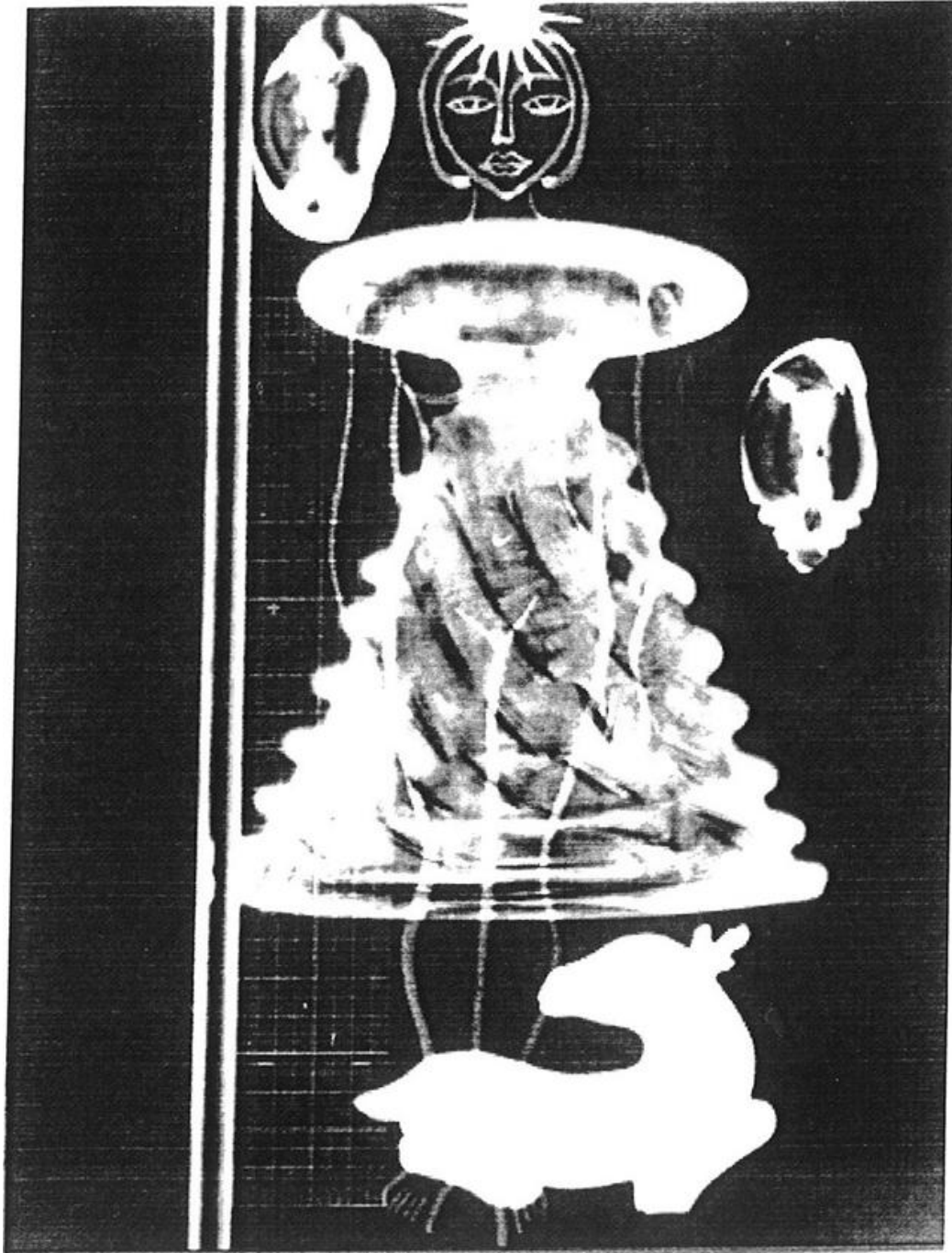

Rosa Rolanda (United States, 1895–1970, active Mexico)
Drawing Photogram, c. late 1920s
Gelatin silver print photogram, 8³/₈ x 6¹/₂ in.
Collection of Adriana Williams
© Rosa Covarrubias. Photo © Courtesy of Historical Design Inc., New York, NY

Las dos Fridas (The Two Fridas), 1939

FRIDA KAHLO (MEXICO, 1907–1954, ACTIVE MEXICO AND UNITED STATES)

Kahlo's self-portraits are beautiful for the same reason as Rembrandt's: They show us the successive identities of a human being who is not yet, but who is becoming.

—Carlos Fuentes²

LAS DOS FRIDAS (THE TWO FRIDAS) IS USUALLY CONSIDERED Kahlo's masterpiece. Exceptionally large in scale, it was painted after her divorce from artist Diego Rivera (Mexico, 1886–1957) in 1939. *Separation* and *identity* are two key words to decipher this painting, the meaning of which has been variously interpreted by many art historians.

Two versions of the same woman are seated on a bench before a stormy sky. The starkness of the composition forces the viewer to focus on the figures. Sitting hand in hand, the women are similar but not identical. Both have an elaborate upswept hairdo, dramatic eyebrows that join in the middle, and a downy mustache accentuated by red lips. Found in the majority of the artist's self-portraits, these features are instantly recognizable as belonging to Frida Kahlo.

- Compare and Contrast: What is similar about these two figures? How are they different? Do you think they represent two separate people or one person? What do you see that makes you say that? Craft an argument using visual characteristics to support your claim.

One Frida is dressed in a feminine, Victorian-style garment, with a lace bodice and embroidery around the flounce hem of the skirt. Her expression is calm and emotionally unreadable. Her gaze does not confront the viewer; she looks down and toward her right. The bodice of her gown is cut open to reveal a heart that has been sliced in half. The surgical clamps, attached to an artery, have not stopped the flow of blood, and it falls onto her white dress.

The other Frida has slight, subtle differences in the coloring of face, her expression, her gaze, and the details of her hairdo. Her hand supports that of the Victorian Frida, and she wears garments that may be

from the same era as her companion but are obviously not of the same culture. The clothing is utilitarian: a blue and orange blouse and a green skirt. Her half of the heart sits exposed outside her blouse. The artery wraps around her arm and ends in a small oval image of a boy, labeled "Diego."

The clothing the two women wear also represents two halves of the whole. The Victorian dress may represent the mestiza Kahlo, who was born to a European father and a Mexican mother. The traditional Mexican dress, which Kahlo used to create her public persona, had cultural references to the matriarchal Tehuana society and to the indigenous movement that gained traction after the Mexican Revolution. In her journal, Kahlo also refers to her personal color code, in which the green color of the skirt refers to ghosts and sadness.

- Color Code: Look at a color wheel and place the colors into warm and cool categories. Warm colors (red, orange) are vivid and energetic, while cool colors (blue, green) inspire calm and tranquility. Make a list of emotions such as joy, sadness, jealousy, and anger, and assign each a color that best captures that feeling. Use your color code to create a monochromatic work that explores the shades of a singular color or emotion.

The anatomically accurate rendering of the heart is another distinguishing characteristic of Kahlo's work. In her youth, she had been involved in a serious traffic accident, and the injuries she sustained required that she have dozens of surgeries throughout her life, making her intimately familiar with the workings of the human body. While Kahlo was bedridden and recovering from the accident, her mother gave her a mirror and paints and she began creating self-portraits.



Frida Kahlo (Mexico, 1907–1954, active Mexico and United States)

Las dos Fridas (The Two Fridas), 1939

Oil on canvas, 68³/₈ x 68¹/₂ in.

Museo de Arte Moderno, Mexico City

© Banco de México Diego Rivera Frida Kahlo Museums Trust, Mexico, D.F. / Artists Rights Society (ARS), New York.

Reproduction of Frida Kahlo governed by Instituto Nacional de Bellas Artes y Literatura.

Photo © Museo de Arte Moderno, Mexico City

- Diptych Portrait: We express different facets of our personality in the various contexts of our lives, whether at school with teachers, at home with family, or with friends. Draw a simple self-portrait with just yourself in the foreground. Make a photocopy of the drawing so that you have two copies. Now think about two different contexts, places, or landscapes. Add a back-

ground to each of your self-portraits that illustrates these places. In the middle ground, include objects and people that depict the action happening in each place. Refer to the color code from the previous activity, and use a color scheme for each scene that captures the feelings you experience in each place. Display the images side by side as a diptych.

Double Portrait of the Artist in Time, 1935

HELEN LUNDEBERG (UNITED STATES, 1908–1999)



Helen Lundeberg (United States, 1908–1999)

Double Portrait of the Artist in Time, 1935

Oil on Masonite, 47¼ x 40 in.

Smithsonian American Art Museum, Washington, DC, museum purchase

© The Feitelson / Lundeberg Art Foundation. Reproduced by Permission.

Photo © Smithsonian American Art Museum, Washington, DC / Art Resource, NY

IN THESE PAINTINGS HELEN LUNDEBERG, A CALIFORNIA artist and the most important woman surrealist on the West Coast, has presented three self-portraits. A blond toddler is sitting on a small stool next to a table with a piece of paper and a clock on it. Wearing an old-fashioned white dress and black Mary Janes, the child grasps a stem of flower buds in one hand and her skirt in the other. Her gold hair and smiling face are reinforced by the painting's warm tones, which create an inviting domestic scene. A shadow representing the passage of time links the toddler to the adult in the portrait behind her. The framed profile portrait depicts a woman leaning on a table or shelf. Like the child, she holds a flower, but hers is blossoming, and she contemplates a small container representing a globe. (The framed portrait, *Artist, Flowers, and Hemispheres*, 1934, is in the

collection of the San Francisco Museum of Modern Art; <http://www.sfmoma.org/explore/collection/artwork/43>.)

Lundeberg has faithfully reproduced an image from a childhood photograph; the clock, set at quarter past two, indicates the girl's age. According to the artist, she placed the child in front of the portrait, so "the child casts a shadow which is that of an adult who appears in the portrait on the wall . . .".³ Lundeberg has changed the laws of nature by reversing the passage of time. The impossibility of a child casting an adult shadow lies well within the improbability factor of the surrealist vocabulary.

- Compare and contrast this double portrait with the self-portrait by Frida Kahlo on the previous page. What is similar? What is different? How does each artist construct her unique identity?

Self-Portrait (with Landscape), 1944

HELEN LUNDEBERG (UNITED STATES, 1908–1999)



Helen Lundeberg (United States, 1908–1999)
Self-Portrait (with Landscape), 1944
Oil on Masonite, 15¾ x 27¼ in.

Zimmerli Art Museum at Rutgers University, New Brunswick, New Jersey
Gift of the Lorser Feitelson and Helen Feitelson Lundeberg Foundation

© The Feitelson / Lundeberg Art Foundation. Reproduced by Permission. Photo © Jack Abraham

IN THIS PAINTING, A YOUNG WOMAN GAZES DIRECTLY AT THE viewer. She appears in front of a painting, with a paintbrush in her left hand and an orb in her right. This choice of a "painting within a painting" was a technique used by other surrealists. Through her art, Lundeberg explores the connection between the cosmos and the self. In *Self-Portrait (with Landscape)*, the representation of deep space in the painting within the painting reflects a concern with universal or metaphysical (the relationship of humans to nature and the universe) themes and recurs in her work, such as *Microcosm and Macrocosm*, 1937 (see the enclosed CD).

- **Snapshots:** In these self-portraits, Lundeberg has provided snapshots of herself at different times in her life. Choose three photographs from your life that you view as defining moments. How do they reflect your interests or passions?

In 1934, Lundeberg and her husband, artist Lorser Feitelson (United States, 1898–1978), issued the first and only surrealist manifesto to originate in

the United States. The publication was titled *New Classicism*, and in it the two artists emphasized that their creative process was conscious and orderly, in contrast to the European surrealists, who denied that there was any conscious intrusion in their aesthetic practices. Lundeberg's innate sense of order and structure, her preference for the rational over the emotional, and her attraction to cosmological relationships are evident in both *Self-Portrait (with Landscape)* and *Double Portrait of the Artist in Time*.

- **Dreams and Reality:** Many surrealists sought to depict the passage of time (for example, Salvador Dali's *Persistence of Memory*, 1931, now in the collection of the Museum of Modern Art; http://www.moma.org/collection/object.php?object_id=79018). Compare how time passes in the real world with how it passes in dreams. Which parts of Lundeberg's paintings seem realistic, and which parts seem as if they originated in a dream?

Sirenas del aire (Mermaids of the Air)

LOLA ALVAREZ BRAVO (MEXICO, 1907–1993) C. 1935–36, PRINTED C. 1958

WITH *SIRENAS DEL AIRE (MERMAIDS OF THE AIR)*,

Alvarez Bravo offers a pairing of the modern and the classical world using the surrealist approach of juxtaposing improbable objects. Two mermaids, their backs to the viewer, float on an empty picture plane. These mermaids (or sirens) no longer perform their traditional role of singing to enchant unwary sailors; rather, they have chosen a more modern vehicle to send their messages, the typewriter. The title also demonstrates the surrealist penchant for combining unlikely elements, as mermaids do not claim the sky as habitat.

Although the format of the composition is contained within a rectangular frame, the gentle curves of the mermaids' bodies suggest a circular format. By following the invisible lines formed by their tails, we can imagine a circle bisected by the bodies to create a *taijitu*, the Chinese symbol for yin and yang, complementary opposites that compose a greater whole. While the mermaids are not mirror images of each other, there is a sense of balance and harmony, with the typewriter as the center of a symbolic universe. To underscore this pairing of opposites, Alvarez Bravo brings together images that suggest technology and classicism, fantasy and reality, couched in a dialogue about women's roles. The montage's intentional ambiguity allows for multiple interpretations. The hand of the mermaid in the upper right extends beyond the picture plane, implying that the action continues outside the margins. The emptiness of the background invites the viewer to create a visual and verbal narrative for this image: Where did the mermaids come from? Where are they now? What are they doing?

At the time this photomontage was made in the mid-1930s, the typewriter was a symbol of modernity. It could also be considered a symbol of liberation for women, allowing them to leave their homes, farms, or menial labor jobs for a more professional position in an office.

Alvarez Bravo actively participated in promoting women's rights; this image alludes to her interest in using art to comment on social justice issues. In addition to creating photomontages with strong elements of journalism, she pushed the boundaries of photography beyond pure documentation, working as a photojournalist, a portrait photographer, and an architectural photographer. She was briefly married to photographer Manuel Alvarez Bravo (Mexico, 1902–2002) and learned photography by assisting him.

- **Messaging:** The lower mermaid rests her hands on the typewriter as if she is about to strike a key. If she types a message for us, the viewers, what would the message say? What message do you think the artist was trying to convey in 1935–36, when the photomontage was made?
- **Technology:** Today, the typewriter is almost obsolete. Is there a contemporary piece of technology that you would substitute for the typewriter in this artwork? Would your updated version change the artwork's message? How so? Think about the types of technology that you encounter today—computers and the Internet, cell phones, etc. Choose one of these to send a message to students in the future. What would you tell them about your life, your community, and your world today? What do you feel are the major accomplishments of your time and what do you hope these students will see in the future?

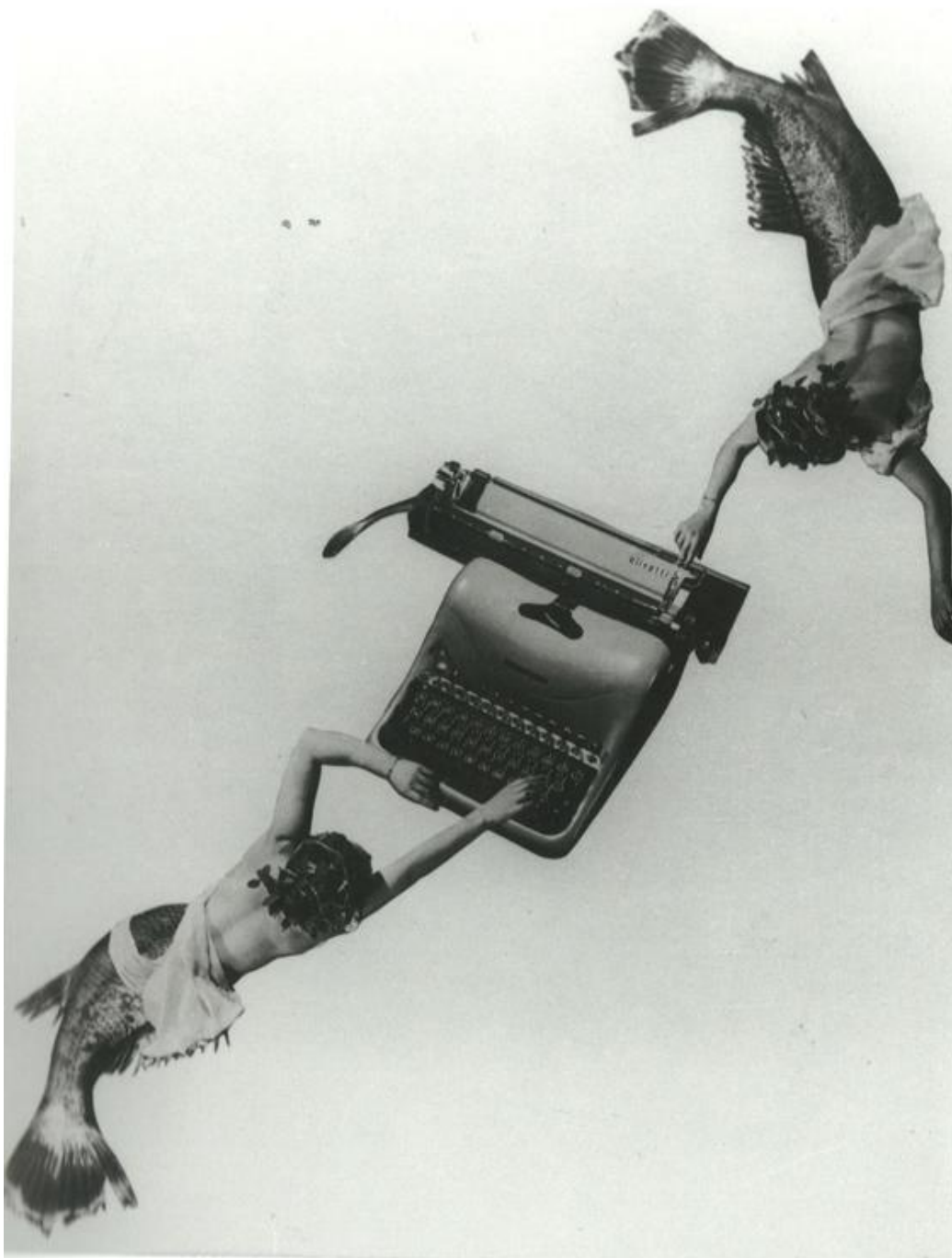

Lola Alvarez Bravo (Mexico, 1907–1993)
Sirenas del aire (*Mermaids of the Air*), c. 1935–36, printed c. 1958
Gelatin silver print photomontage, 7¹/₈ x 6 in.
Private collection, courtesy Galería Enrique Guerrero, Mexico City
© 1995 Center for Creative Photography, The University of Arizona Foundation.
Photo © Museum Associates/LACMA, by Jorge Pérez de Lara

Notes

¹ Tere Arcq, "In the Land of Convulsive Beauty: Mexico," in *In Wonderland: The Surrealist Adventures of Women Artists in Mexico and the United States*, ed. Ilene Susan Fort and Tere Arcq, with Terri Geis (Los Angeles: Los Angeles County Museum of Art, DelMonico Books Prestel, 2012), p. 83.

² Carlos Fuentes, introduction to *The Diary of Frida Kahlo: An Intimate Self-Portrait*, by Frida Kahlo (New York: Harry N. Abrams, 1995), p.16.

³ Henry J. Seldis, introduction to *Helen Lundeberg: A Retrospective Exhibition* (La Jolla, CA: La Jolla Museum of Contemporary Art, 1971), p.2.

This exhibition was organized by the Los Angeles County Museum of Art (LACMA) and the Museo de Arte Moderno, Mexico. It was made possible through a generous grant from the Terra Foundation for American Art. The organizers are grateful for the special collaboration of the National Council for Culture and the Arts (Conaculta), Mexico, and National Institute of Fine Arts (INBA), Mexico. The Los Angeles presentation was made possible in part by The Mr. and Mrs. Raymond J. Horowitz Foundation for the Arts and is supported by an indemnity from the Federal Council on the Arts and the Humanities.

TERRA
FOUNDATION FOR AMERICAN ART

CONACULTA

 Instituto
Nacional de
Bellas Artes

These curriculum materials were written and edited by Lynn LaBate, Rachel Bernstein, and Jennifer Reid, and designed by Jenifer Shell, with selections adapted from the exhibition text and catalogue for *In Wonderland: The Surrealist Adventures of Women Artists in Mexico and the United States*. Copyright © 2012 Museum Associates/Los Angeles County Museum of Art. All rights reserved.

Evenings for Educators is presented by **CHASE**

Additional funding is provided by the Joseph Drown Foundation, Thomas and Dorothy Leavey Foundation, and the Kenneth T. and Eileen L. Norris Foundation.

Education programs at the Los Angeles County Museum of Art are supported in part by the City of Los Angeles Department of Cultural Affairs, the William Randolph Hearst Endowment Fund for Arts Education, and Rx for Reading.

 **DCA** DEPARTMENT OF CULTURAL AFFAIRS
City of Los Angeles



LACMA | Evenings for Educators | February 7, 2012

In Wonderland: The Surrealist Adventures of Women Artists in Mexico and the United States

About the Exhibition

Driven by an impulse for independence and self-expression, women surrealist artists such as Frida Kahlo, Leonora Carrington, Helen Lundeborg, and others were masters at using art to subvert traditional notions of gender, sexuality, and motherhood. The first large-scale survey of its kind, *In Wonderland* brings together approximately one hundred and seventy-five surrealist works by forty-seven women artists including painting, sculpture, photography, and other works on paper. During wartime, the geographic landscapes of Mexico and the United States allowed these artists to freely delve deep into their subconscious and dreams to create art that shocks, delights, and amazes. *In Wonderland* journeys through their fantastical worlds and bears witness to their relentless self-discovery. The exhibition is on view January 29–May 6, 2012 in the Resnick Pavilion at LACMA.

About this Resource

Designed as a complement to the Evenings for Educators program, Surrealism and Women Artists, this resource highlights a selection of artists featured in the exhibition. These twentieth-century artists represent different aspects of surrealism, for example: Frida Kahlo's continual reinvention of persona, Helen Lundeborg's classical representations, Lola Alvarez Bravo's concern for social justice, and Rosa Rolanda's lesser-known autobiographical and experimental work.

The themes that dominated the work of women surrealists in Mexico and the United States reflected the artists' past experiences, present-day situations, fears, hopes, and desires. These artists also helped set the stage for the feminist movement by creating art that challenged established social institutions and gender boundaries. Because much of the art of women surrealists was self-referential in nature, portraiture was an ideal vehicle for exploring identity. Within that genre, self-portraits were

essential, whether they were presented as straightforward depictions, autobiographical or fabricated stories, or symbolic still lifes.

Share the enclosed images with your students. Use or adapt the following discussion questions and activities to your students' diverse needs and learning styles.

- **Medium & Message**—Surrealist artists experimented with a variety of visual media such as painting, photography, photogram, collage, and montage. Study the artworks in this curriculum and think about the messages they convey. How does the artist's choice of medium help express this message? Write this message in your own words using a literary medium such as narrative or poetry.
- **Manipulating Reality**—An uncanny distortion of perspective unites many surrealist works. Pick one of the enclosed artworks to study and consider how the artist plays with space to create an illusion through the manipulation of perspective, depth, or scale.
- **Image & Identity**—Think about all the ways you can produce a self-portrait—through drawing, painting, photography, even writing (i.e. autobiography). A portrait can not only capture a person's likeness but also his or her personality, interests, and life story. Make a list of words that describe your personality, such as your favorite colors, places, and things to do. Include many of these characteristics in a self-portrait that tells us about you. Consider the setting, what you will hold, what you will wear, and the pose you will take. Supplement the composition with symbolism and imagery that are important to your heritage or to your family's background or country of origin.

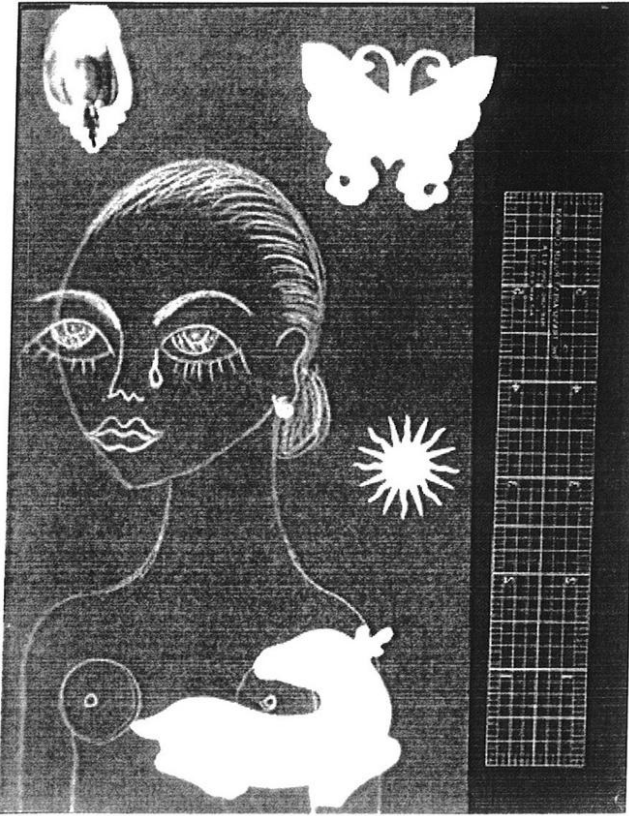

ROSA ROLANDA
(United States, 1895–1970, active Mexico)
Self-Portrait Photogram, c. late 1920s
Gelatin silver print photograms, 8³/₈ x 6¹/₂ in.
Collection of Adriana Williams. © Rosa Covarrubias.
Photo © Courtesy of Historical Design Inc., New York, NY

ROSA ROLANDA
BORN 1895, AZUSA, CALIFORNIA
DIED 1970, MEXICO CITY, MEXICO

Originally from California, Rosa Rolanda began her career in New York in 1916 as a celebrated Broadway dancer. Rolanda was introduced to the photogram technique—that is, cameraless photographs—in the 1920s, either during her tour as a dancer with the Ziegfeld Follies in 1923, when painter and photographer Man Ray (United States, 1890–1976) photographed her, or after she and her husband, the artist Miguel Covarrubias (Mexico, 1904–1957), returned to Paris in September, 1926.

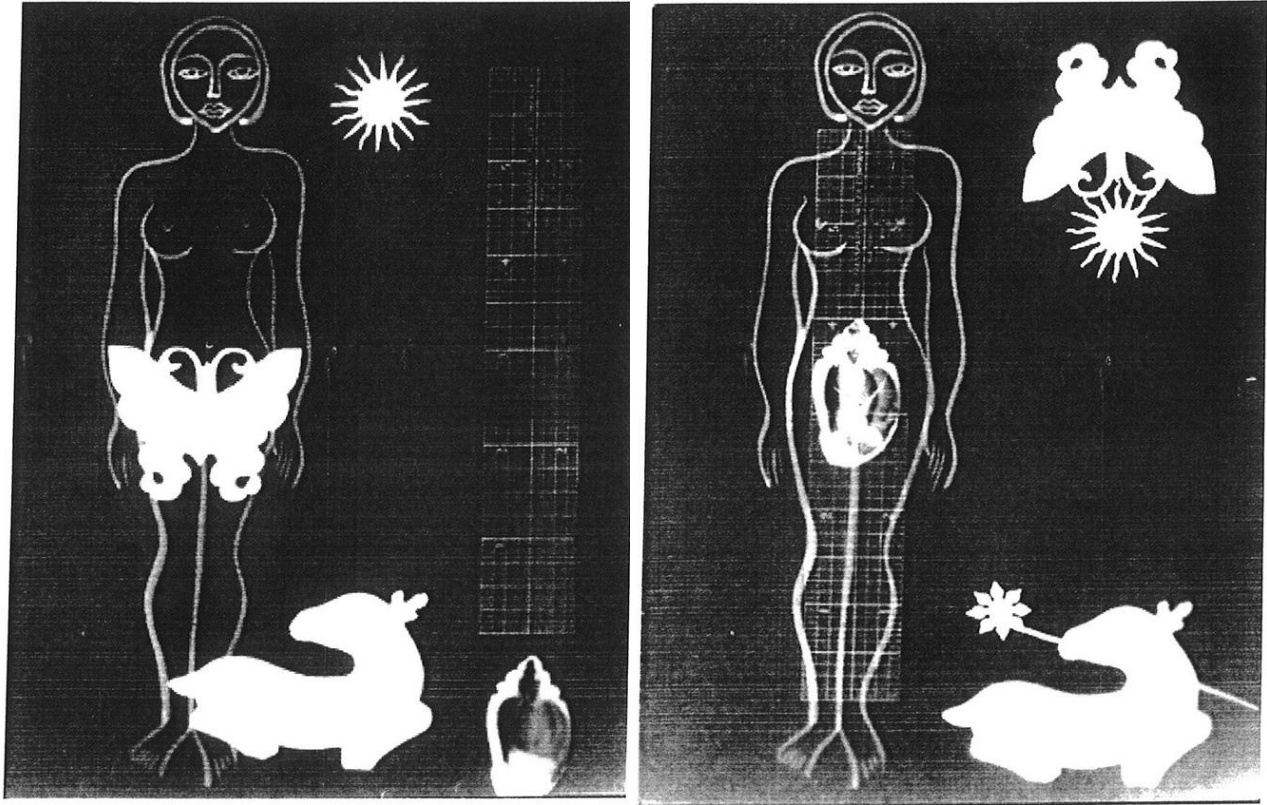

ROSA ROLANDA

(United States, 1895–1970, active Mexico)

Drawing Photograms, c. late 1920s

Gelatin silver print photograms, each: 8½ x 6½ in.

Collection of Adriana Williams

© Rosa Covarrubias. Photo © Courtesy of Historical Design Inc., New York, NY

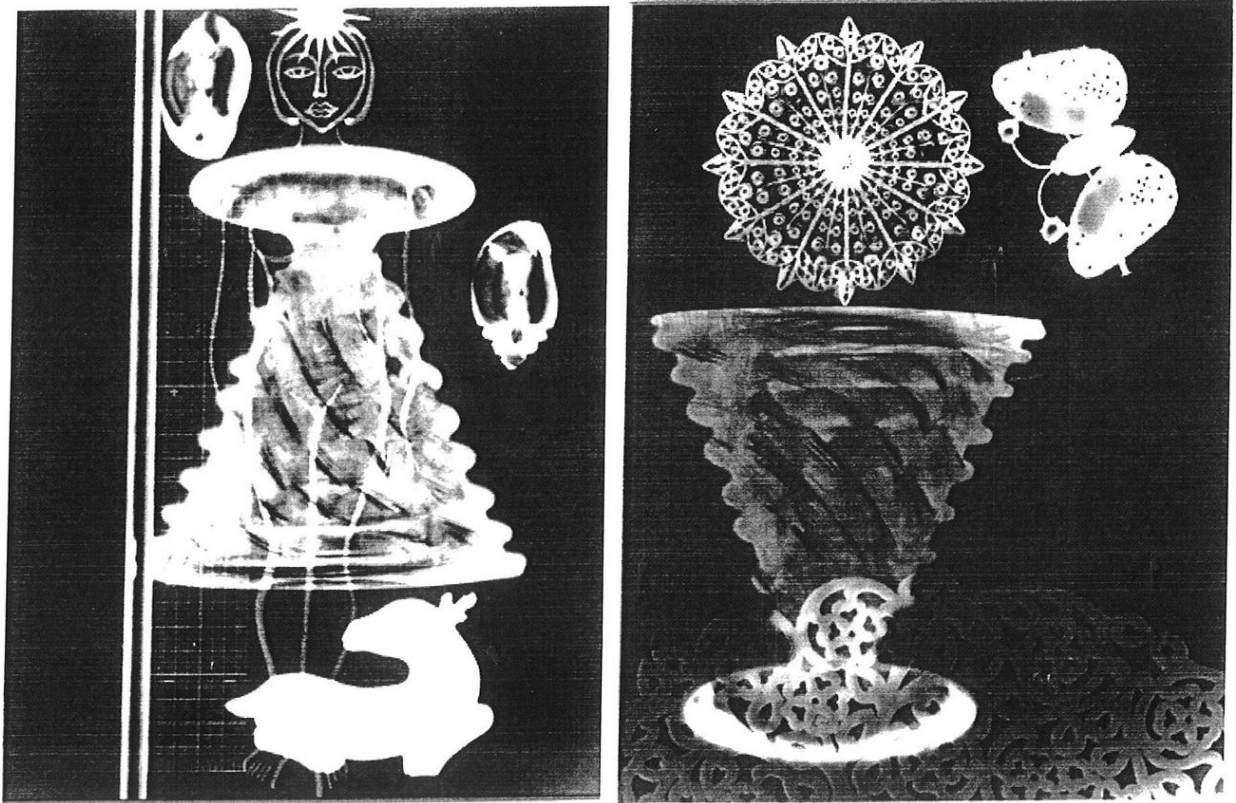

ROSA ROLANDA

(United States, 1895–1970, active Mexico)

Drawing Photograms, c. late 1920s

Gelatin silver print photograms, each: 8½ x 6½ in.

Collection of Adriana Williams

© Rosa Covarrubias. Photo © Courtesy of Historical Design Inc., New York, NY



ROSA ROLANDA

(United States, 1895–1970, active Mexico)

Autorretrato (Self-Portrait), 1952

Oil on canvas, 33⁷/₈ x 43³/₈ in.

Museo de Arte Moderno, Mexico City

© Rosa Rolanda, Courtesy Blaisten Collection. Photo © Francisco Kochen



FRIDA KAHLO

(Mexico, 1907–1954, active Mexico and United States)

Cocos gimientes (Weeping Coconuts), 1951

Oil on board, 9 $\frac{1}{8}$ x 12 in.

Los Angeles County Museum of Art

The Bernard and Edith Lewin Collection of Mexican Art (M.2004.283.2)

© 2012 Banco de Mexico Diego Rivera & Frida Kahlo Museum Trust

Reproduction of Frida Kahlo governed by Instituto Nacional de Bellas Artes y Literatura.

Photo © 2012 Museum Associates/LACMA

FRIDA KAHLO

BORN 1907, COYOACÁN, MEXICO

DIED 1954, COYOACÁN, MEXICO

Frida Kahlo is best known for her highly personal self-portraits, in which she utilized imagery from Mexican folk art and pre-Columbian symbolism. Kahlo began to paint in 1925, while recovering from a streetcar accident that left her permanently disabled. She underwent more than thirty operations, and many of her approximately two hundred paintings explore her experiences with pain. They also chronicle her turbulent relationship with Mexican muralist Diego Rivera (Mexico, 1886–1957), whom she married in 1929.



FRIDA KAHLO

(Mexico, 1907–1954, active Mexico and United States)

Las dos Fridas (The Two Fridas), 1939

Oil on canvas, 68³/₈ x 68¹/₂ in.

Museo de Arte Moderno, Mexico City

© Banco de México Diego Rivera Frida Kahlo Museums Trust, Mexico, D.F.

/ Artists Rights Society (ARS), New York.

Reproduction of Frida Kahlo governed by Instituto Nacional de Bellas Artes y Literatura.

Photo © Museo de Arte Moderno, Mexico City



HELEN LUNDEBERG

(United States, 1908–1999)

Self-Portrait (with Landscape), 1944

Oil on Masonite, 15¼ x 27¼ in.

Zimmerli Art Museum at Rutgers University, New Brunswick, New Jersey

Gift of the Lorser Feitelson and Helen Feitelson Lundeberg Foundation

© The Feitelson / Lundeberg Art Foundation.

Reproduced by Permission. Photo © Jack Abraham

HELEN LUNDEBERG

BORN 1908, CHICAGO, ILLINOIS

DIED 1999, LOS ANGELES

Helen Lundeberg sought to create art that would reveal the subconscious workings of the mind in a rational way. In 1933 Lundeberg and her husband, Lorser Feitelson (United States, 1898–1978), founded the so-called New Classicism movement and in 1934 they issued its manifesto—the sole manifesto issued by a group in the United States to respond to European surrealism.



HELEN LUNDEBERG

(United States, 1908–1999)

Double Portrait of the Artist in Time, 1935

Oil on Masonite, 47 $\frac{3}{4}$ x 40 in.

Smithsonian American Art Museum, Washington, DC, museum purchase

© The Feitelson / Lundeberg Art Foundation. Reproduced by Permission.

Photo © Smithsonian American Art Museum, Washington, DC / Art Resource, NY



HELEN LUNDEBERG

(United States, 1908–1999)

Microcosm and Macrocosm, 1937

Oil on Masonite, 38¼ x 13¼ in.

Los Angeles County Museum of Art, purchased with funds
provided by Mr. and Mrs. Robert B. Honeyman Jr. (M.2003.50)

© The Feitelson / Lundeberg Art Foundation. Reproduced by Permission.

Photo © 2012 Museum Associates/LACMA



HELEN LUNDEBERG
(United States, 1908–1999)
The Shell, 1951

Oil on canvas, 30 x 36 in.

Los Angeles County Museum of Art, gift of the Feitelson Revocable Trust (M.89.108)

© The Feitelson / Lundeberg Art Foundation. Reproduced by Permission.

Photo © 2012 Museum Associates/LACMA

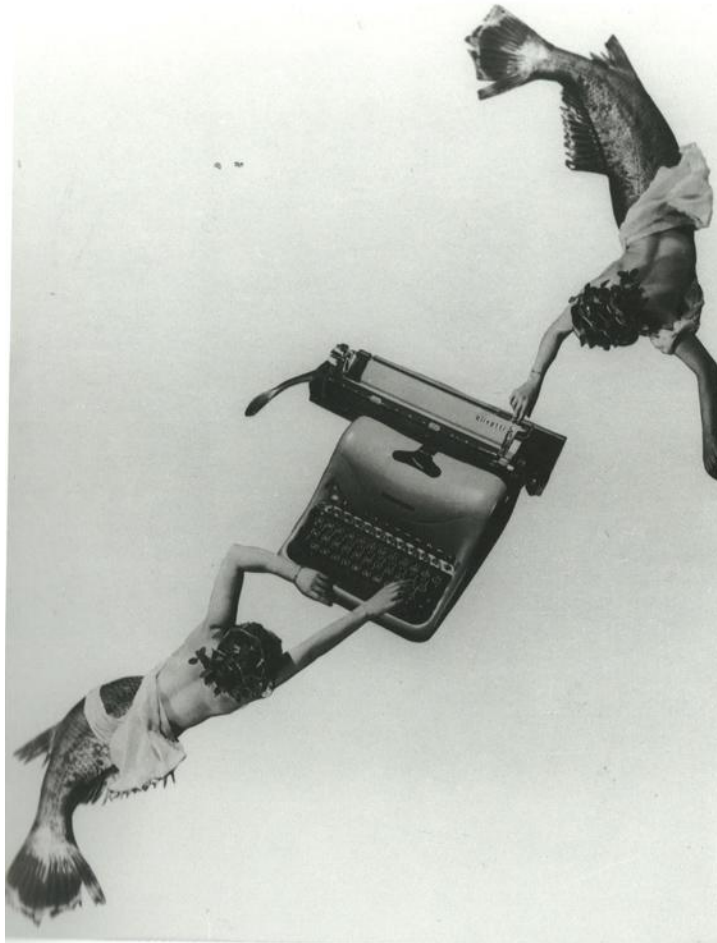

LOLA ALVAREZ BRAVO
(Mexico, 1907–1993)

Sirenas del aire (Mermaids of the Air), c. 1935–36, printed c. 1958
Gelatin silver print photomontage, 7⁷/₈ x 6 in.

Private collection, courtesy Galería Enrique Guerrero, Mexico City
© 1995 Center for Creative Photography, The University of Arizona Foundation.
Photo © Museum Associates/LACMA, by Jorge Pérez de Lara

LOLA ALVAREZ BRAVO
BORN 1907, LAGOS DE MORENO, MEXICO
DIED 1993, MEXICO CITY, MEXICO

Lola Alvarez Bravo actively participated in promoting women's rights and used her art to comment on social justice and civic issues. In addition to creating photomontages with strong elements of journalism, she pushed the boundaries of photography beyond pure documentation, working as a photojournalist, a portrait photographer, and an architectural photographer. She was briefly married to photographer Manuel Alvarez Bravo (Mexico, 1902–2002) and learned photography by assisting him.



LOLA ALVAREZ BRAVO

(Mexico, 1907–1993)

Unos suben y otros bajan (Some Rise and Others Fall). c. 1940s

Gelatin silver print, 9 $\frac{1}{8}$ x 6 $\frac{7}{8}$ in.

Center for Creative Photography, University of Arizona, Tucson:
Lola Alvarez Bravo Archive Collection Center for Creative Photography,
University of Arizona © 1995 The University of Arizona Foundation



LEONORA CARRINGTON

(England, 1917–2011, active France, Mexico, and United States)

Self-Portrait, c. 1937–38

Oil on canvas, 25³/₈ x 32 in.

The Metropolitan Museum of Art

The Pierre and Maria-Gaetana Matisse Collection, 2002 (2002.456.1)

© 2011 Leonora Carrington / Artists Rights Society (ARS), New York

Photo © The Metropolitan Museum of Art / Art Resource, NY

LEONORA CARRINGTON

BORN 1917, LANCASHIRE, ENGLAND

DIED 2011, MEXICO CITY, MEXICO

Over a career of more than seventy years, Leonora Carrington created a mythical and often humorous world of human-animal hybrids in her paintings, sculptures, and stories. In 1937 Carrington settled with the surrealist painter Max Ernst in France. She participated in the International Exhibition of Surrealism in Paris and later immigrated to Mexico City.



LEONORA CARRINGTON

(England, 1917–2011, active France, Mexico, and United States)

Maja del tarot (Double Portrait of María Félix), 1965

Oil on canvas, 79¹/₈ x 70¹/₂ in.

Collection of the Artemundi Group

© 2011 Leonora Carrington / Artists Rights Society (ARS), New York.

Photo courtesy of a private collection.



RUTH BERNHARD
(Germany, 1905–2006, active United States)
In the Box—Horizontal, 1962
Gelatin silver print, 25 x 35¾ in.
Los Angeles County Museum of Art, gift of the Estate of Ruth Bernhard (M.2007.155)
Reproduced with permission of the Ruth Bernhard Archive
Princeton University Art Museum. © Trustees of Princeton University
Photo © Museum Associates/LACMA

RUTH BERNHARD
BORN 1905, BERLIN, GERMANY
DIED 2006, SAN FRANCISCO

Best known for her photographs of female nudes, Ruth Bernhard also regularly photographed dolls and puppets, which she placed in uncanny and humorous juxtapositions. As she said later, "I don't plan things; they plan for me. Photographs speak to me and I obey."



LEE MILLER

(United States, 1907–1977, active England, France, Egypt, and United States)

Solarized Portrait of Dorothy Hill (Profile), 1932

Gelatin silver print, 9½ x 7½ in.

Lee Miller Archives, England

© Lee Miller Archives, England 2011. All rights reserved. www.leemiller.co.uk

LEE MILLER

BORN 1907, POUGHKEEPSIE, NEW YORK

DIED 1977, CHIDDINGLY, EAST SUSSEX, ENGLAND

Lee Miller's photography encompassed a wide range of imagery—from the world of high fashion to the atrocities of World War II—and captured surprising juxtapositions with surrealist black humor. She studied in Paris with the surrealist photographer Man Ray, from whom she learned many progressive photographic techniques.

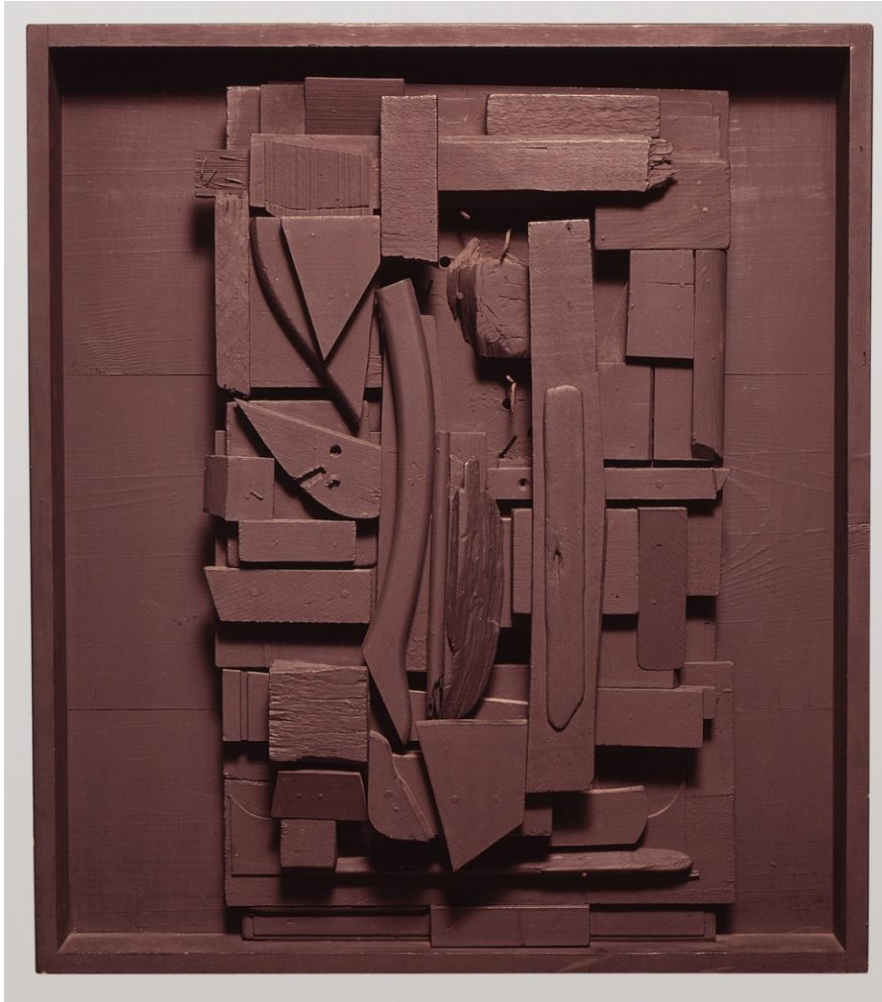

LOUISE NEVELSON

(Russia, 1900–1988, active United States)

Verso, 1959

Wood and black paint relief, 32¹/₈ x 28³/₁₆ x 3³/₁₆ in.

Los Angeles County Museum of Art

Gift of Mr. and Mrs. Michael Blankfort through the Contemporary Art Council (M.73.80)

© 2011 Estate of Louise Nevelson / Artists Rights Society (ARS), New York.

Photo © 2012 Museum Associates/LACMA

LOUISE NEVELSON

BORN 1900, KIEV, RUSSIA (NOW KIEV, UKRAINE)

DIED 1988, NEW YORK, NEW YORK

Described by the art historian Dore Ashton as the "grand mistress of the marvelous," Louise Nevelson is best known for her assemblages of found objects. She worked as an assistant to Diego Rivera, and later visited pre-Columbian ruins where she gained inspiration for the scale and geometry that mark most of her significant mature works.



DOROTHEA TANNING

(United States, b. 1910, active United States and France)

Xmas, 1969

Fabric, metal, and wool, body: 69⁵/₈ x 19³/₄ x 20¹/₂ in.; appendage: 4³/₈ x 3¹/₂ x 7⁷/₈ in.

Los Angeles County Museum of Art, purchased with funds provided by the 2010 Collectors Committee, with additional funds generously provided by Jodie Evans with Lekha Singh, The Rosenthal Family Foundation, Peg Yorkin, the Kayne Foundation, and Susan Adelman in honor of the artist's 100th birthday, Irene Christopher, Viveca Paulin-Ferrell, American Art Deaccession Funds, Janice G. Gootkin, The Eileen F. and Mort H. Singer, Jr.

Family fund in honor of Ilene Susan Fort, and J. Patrice Marandel (M.2010.36a–b)

© 2011 Artists Rights Society (ARS), New York / ADAGP, Paris

Photo © 2012 Museum Associates/LACMA

DOROTHEA TANNING

BORN 1910, GALESBURG, ILLINOIS

Dorothea Tanning is one of the foremost surrealists in the United States. In her early paintings she depicted quiet interiors featuring young women in mysterious, emotional states. Tanning married Max Ernst in 1946, and later the couple moved to France, where Tanning began to work in a more abstract style that included soft sculptures like the one above in LACMA's collection.

Cover: Frida Kahlo, *Self-Portrait with Thorn Necklace and Hummingbird (Autorretrato con collar de espinas y colibrí)*, 1940, Harry Ransom Humanities Research Center, The University of Texas at Austin, © 2011 Banco de México Diego Rivera Frida Kahlo Museums Trust, México, D.F./ Artists Rights Society (ARS), New York, reproduction of Frida Kahlo governed by Instituto Nacional de Bellas Artes y Literatura (INBA)

This exhibition was organized by the Los Angeles County Museum of Art (LACMA) and the Museo de Arte Moderno, Mexico. It was made possible through a generous grant from the Terra Foundation for American Art. The organizers are grateful for the special collaboration of the National Council for Culture and the Arts (Conaculta), Mexico, and National Institute of Fine Arts (INBA), Mexico. The Los Angeles presentation was made possible in part by The Mr. and Mrs. Raymond J. Horowitz Foundation for the Arts and is supported by an indemnity from the Federal Council on the Arts and the Humanities.

TERRA
FOUNDATION FOR AMERICAN ART

CONACULTA

 Instituto
Nacional de
Bellas Artes

These curriculum materials were written and edited by Lynn LaBate, Rachel Bernstein, and Jennifer Reid, and designed by Jenifer Shell, with selections adapted from the exhibition text and catalogue for *In Wonderland: The Surrealist Adventures of Women Artists in Mexico and the United States*. Copyright © 2012 Museum Associates/Los Angeles County Museum of Art. All rights reserved.

Evenings for Educators is presented by **CHASE** 

Additional funding is provided by the Joseph Drown Foundation, Thomas and Dorothy Leavey Foundation, and the Kenneth T. and Eileen L. Norris Foundation.

Education programs at the Los Angeles County Museum of Art are supported in part by the City of Los Angeles Department of Cultural Affairs, the William Randolph Hearst Endowment Fund for Arts Education, and Rx for Reading.

 **DCA** DEPARTMENT OF CULTURAL AFFAIRS
City of Los Angeles

Classroom Activity

Imagining the Subconscious through Collage

Enduring Understanding	Artists often use artmaking to communicate messages about their interior life and personal thoughts.
Grades	K–12
Time	One to two class periods
Visual Art Concepts	Silhouette, drawing, collage, juxtaposition, deconstruction and reconstruction
Materials	Black drawing paper, graphite pencils or white drawing pencils, overhead projector or flashlights, glue, scissors, and collage materials such as art reproductions, newspaper, photographs, magazines, or wrapping, patterned, or decorative paper.
Talking about Art	<p>View and discuss Lola Alvarez Bravo's <i>Sirenas del aire (Mermaids of the Air)</i>, c. 1935-36, printed c. 1958.</p> <p>What do you see? What action is taking place? Who are the main characters and what might they be saying? What are they using to communicate this message? Have you seen this device before? Where and when? Does it give us a clue as to when this photograph was made?</p> <p>Like the typewriter, art, too, is a medium for communicating messages. What message do you think the artist, Lola Alvarez Bravo, might have been trying to communicate in 1935 through this photograph? What communication devices do you use today? If you replaced the typewriter in this image with your device of choice, how would it change the intended message?</p> <p>Elaborate on this message by writing a caption for this photograph in the form of a tagline, a dialogue, or a story that explains what <i>you</i> think is happening. Retitle <i>Sirenas del aire (Mermaids of the Air)</i> with a title of your choice.</p> <p>This photograph is a photomontage, meaning it is a composite photograph made from more than one image. What steps do you think Bravo took to create this artwork? Where might she have sourced her images?</p>

The 21st century version of this process is often calling "photoshopping," but both are essentially multi-media collage. A collage is simply an artwork comprised of different shapes, texts, or images layered on top of each other. The term "collage" derives from *colle*, the French word for "glue." The process made its appearance as a formal art medium with the surrealist movement.

Making Art

Use collage as a device for communicating a message about you by creating a multi-media silhouette portrait. Prior to the birth of photography, silhouette profiles cut from black card were the easiest and most inexpensive way of recording a person's appearance. Using your silhouette and favorite images, this metacognitive self-portrait will record your personality and intrapersonal thoughts.

Divide students into groups of three. One student will serve as the portrait sitter, one will handle lighting, and the third will draw the outline of the sitter's head. Consider using your classroom overhead projector or flashlights and white drawing pencil or graphite pencil on large black paper.

Cut the profile out of the black paper. Distribute pieces of large white paper for the collage surface and ask students to brainstorm a list of favorite colors, shapes, animals, images, and places on the back of the white paper. Use this list as inspiration for selecting images from magazines, newspapers, or artwork reproductions. Create a composition using these images and the silhouette cut-out to create a visual landscape of intrapersonal thoughts and interests. Layer the silhouette and images with decorative, patterned, or wrapping papers.

Reflection

Write a short description about yourself to accompany your meta-cognitive self-portrait. Display portraits in the classroom for a "gallery walk" and ask students to match the description with the appropriate collage.

Classroom Activity

Image & Identity: Painted Self-Portraits

Enduring Understanding Artists make many choices about how to represent themselves in a self-portrait. Carefully planned facial expression, body gesture, costume, and accessories can tell us more about the artist's personality or identity and can evoke a certain mood, emotion, or experience.

Grades 3–12

Time One to two class periods

Visual Art Concepts Portraiture, contour drawing, painting, color

Materials Pencils, mirrors, tempera paint such as Alphacolor Biggie Cakes, brushes, watercolor paper, cups of water, and paper towels.
Optional: dry-erase markers, tracing paper, graphite, and hairdryers

Talking about Art A portrait is a picture of a person, where the figure is the focal point of the composition. Artists capture portraits in many media, such as drawing, painting, and photography.

View and discuss Frida Kahlo's *Las Dos Fridas*, 1939. What is similar about these two figures? How are they different? Do you think they represent two separate people or one person? What do you see that makes you say that? Craft an argument using visual characteristics to support your point.

Visual characteristics such as setting, costume, posture, and facial expression can tell us more about the sitter, Frida Kahlo. This is a self-portrait, which means Kahlo painted this portrait of herself, making many important decisions about how she would present her identity. What can we tell about her personality by examining her expression, gesture, and posture? What can we tell about her heritage by examining her dress? Notice that the woman on the left wears a Victorian, or European, style dress with delicate details such as lace and ruffles. Compare and contrast this outfit with what her counterpart wears. The juxtaposition of regional dress may reference Kahlo's *mestiza* or mixed heritage, the product of her European father and Mexican mother. What other messages does Kahlo communicate about her life?

Making Art

Have you ever made a portrait, of yourself or with others? What kinds of decisions went into the creation of your portrait? If you were to paint a self-portrait that expresses a particular emotion, which emotion might you choose and why?

Recall an emotional experience, such as happiness, excitement, frustration, or sadness and brainstorm some possibilities for depicting this experience in a portrait. What type of pose or gesture will you take? What facial expression will best express this emotion? What will you reveal about this experience and what will you choose to conceal through these artistic choices?

What additional elements will you include to tell your story? Consider significant colors, such as warm and cool colors, to create mood. Add information about setting such as place and space, to tell the viewer where you are. Costume and accessories can tell us more about you and your personality. You can also include important symbolism from your culture or heritage to tell about both the past and present.

Now that you have brainstormed ways to represent yourself through a self-portrait, use a mirror to help draw your face or bust. Look in the mirror and trace the outer edge of your reflection, either on watercolor paper with pencil or directly on the mirror with a dry-erase marker. Remember to focus on your image, as opposed to the paper, by tracing the contour of your head, hair, and facial features. Examine and sketch the shapes of your eyes, lips, nose, and ears. Try closing one eye to help you focus.

(If you drew your sketch on the mirror with dry-erase marker, lay a sheet of tracing paper on the mirror and trace the sketch onto the tracing paper with pencil. Take the tracing off the mirror and lay it face down on a sheet of watercolor paper. Rub graphite on the back of the tracing paper and the sketch will transfer onto the watercolor paper.)

Load your brush with water and apply it to the dry tempera cakes to activate the paint. Apply a thin wash to the background area of the self-portrait, with the symbolic color that you chose, to create an overall mood or tone for your painting. Use a dry paper towel to blot or lift color off the wash area to create a textured effect.

Next, try mixing paint to create secondary and tertiary colors for your face, facial features, dress, and accessories. Layer colors on top of each other in short quick strokes. Clean brushes thoroughly in between colors, as tempera is rather opaque. Tempera dries quickly, but, if necessary, use a hairdryer to accelerate drying.

Reflection

Write a short autobiography to accompany your self-portrait. Compare and contrast portraiture in the visual arts with the genre of biography in literature, using classroom texts as examples. What are the benefits and challenges of using art versus writing to tell stories about people?

Classroom Activity

Cameraless Photographic Processes

Enduring Understanding	Photography is an art and a science. Photographers are artists who use light, instead of brushes or pencils, to create images.
Grades	3–12
Time	Two to three class periods
Visual Art Concepts	Line and shape (organic and geometric), negative and positive space, balance, value, contrast, composition, process, abstract and representational
Materials	Light-sensitive paper such as Sunprints, 2D collage materials, scratch paper, cardboard, and water. Optional: matte gel medium, burnishing tools such as spoons or rolling pins, and baby wipes for clean-up.
Talking about Art	<p>View and discuss Rosa Rolanda's <i>Drawing Photogram</i>, c. late 1920s. Compare and contrast with other artworks in Rolanda's photogram series featured on the CD.</p> <p>Describe the shapes that you see, noting the contrast between geometric and organic. Curvy shapes such as circles and ovals are organic shapes, while shapes with straight lines and angles such as squares and triangles are geometric. Use your finger to outline some of these shapes in the air. Which represent or are inspired by shapes from real life? Which shapes are abstract, or non-representational?</p> <p>How do you think Rolanda might have created this image? Some lines appear to be hand-drawn, such as her face and body, while some shapes, such as the animal seated at the figure's feet, look like outlines of unusual or curious objects.</p> <p>Note the value of these shapes. Value is the degree of light and dark in a composition, line, or shape. The contrast between black and white is most evident between the black background and white lines, but take a look at the pyramidal shape in the center. How would you describe the value of this shape? Opaque or translucent? Luminous or dull?</p> <p>The contrasting values were created with light using a cameraless photographic process. Rolanda's image and the accompanying artworks in her series are called photograms. A photogram is a photographic image of objects that have been placed on light-sensitive paper and then exposed to light. During the exposure period, a negative of the composition develops and areas of the paper that have received no light appear white, while areas that have received light appear black. Grey areas result from light traveling through transparent objects. Take a look at the pyramidal shape again. Do you see the inverted glass that Rolanda used to create this effect?</p>

Making Art

Creating photographs without a camera is easier than you think! Ask students to collect an assortment of objects from home, the classroom, or even school grounds. Consider objects or materials of varying sizes with interesting outlines or shapes. The best cameraless photographs utilize objects or materials with holes or gaps in space, such as keys, netting, or plants. These types of materials produce shapes and lines that emphasize negative and positive space. To help students collect objects of appropriate size, determine the scale of the light-sensitive paper in advance (Sunprints come in various dimensions) so that students can limit themselves to objects that will fit within the frame of the paper.

Spread the accumulated source materials out on a desk. Give each student a piece of scratch paper of equal dimension to the Sunprint paper. Arrange objects on the scratch paper to create a composition. Consider compositional balance of positive and negative space and the differing values that they will create.

For best results, close all classroom blinds before you distribute the Sunprint paper (even ambient light will start the exposure process). Carefully arrange objects on the Sunprint paper (blue-side facing up) by removing objects from the scratch paper and placing them one-by-one on the final photographic surface.

Place each Sunprint paper (with its accompanying materials) on a piece of cardboard and leave in the sun for two to five minutes or until the blue background has turned nearly white. Exposure times will vary depending on sunlight, but be sure not to overexpose! Take the print inside, remove all objects from the surface, rinse gently under water or in a small tub for one minute, and allow the print to dry.

Build on your print to create a photographic collage by incorporating other image transfer techniques. For example, photocopy an image or print an image on a laser printer and cut out a selection for reproduction. Apply matte gel medium to the front of the image, adhere the wet image (face down) onto a prepared surface, and burnish the back of the image by rubbing it firmly with a spoon or rolling pin. Dry (with a blow dryer to expedite the drying process) and rub the remaining paper off with water using your fingers until the image is revealed.

Reflection

Visit www.sunprints.org/activities for suggested ways to connect this artistic process with science experiments. Measure the effectiveness of different sunscreens, take pictures of magnetic fields using iron filings, or chart the sun's progress through the sky using the Sunprint paper. For older students, consider extending the lesson by creating a makeshift pinhole camera (visit www.kodak.com and search "pinhole camera") using film and ordinary household materials.

Compare the results of your scientific and photographic experiments with the original photogram. Discuss the nexus of art and science by studying the work of famous artist/scientists such as Leonardo da Vinci and Louis Daguerre.

Classroom Activity

Surrealism & Writing: Pop-Up Bookmaking

Enduring Understanding	The visual and literary arts inform each other. The writer's pencil and the painter's brush are conduits for the artistic imagination.
Grades	6–12
Time	One to two class periods
Visual Art Concepts	Composition (foreground, middle ground, background), bookmaking, paper sculpting techniques (folding, scoring, cutting), positive and negative space, three-dimensionality
Materials	Cardstock, paper, staplers and staples, scissors, and glue or tape. Optional: pencils, rulers, hole punches, colored pencils or decorative paper
Talking about Art	<p>View and discuss Helen Lundeberg's <i>Double Portrait of the Artist in Time</i>, 1935. Compare and contrast with Lundeberg's <i>Self-Portrait (with Landscape)</i>, 1944, and other artworks by Lundeberg featured on the CD.</p> <p>Describe the setting (place and time) of each painting. Who are the main characters, what are they doing, and where are they situated within the artwork?</p> <p>The placement of people, lines, or shapes within an artwork is called composition. Artists often divide a composition according to a figure /ground relationship, meaning objects or subjects occupy space within the foreground, middle ground, or background of a vantage point. Things that appear closest to the viewer, such as the young girl seated in Lundeberg's painting, occupy the foreground. The space furthest from the viewer is the background and the middle ground exists between the foreground and background. Take a closer look at <i>Double Portrait of the Artist in Time</i>, turn to a partner, and explain how the figures interact with each other in space. Is this a realistic viewpoint? Why or why not?</p> <p>The result of Lundeberg's play on space is a disorienting illusion of perspective, depth, and scale. If you could rearrange the elements of the painting, such as the young girl, the table and clock, the shadow, and framed painting, within the foreground, middle ground, and background, how would it change your perception of what's happening in this scene?</p>

Making Art

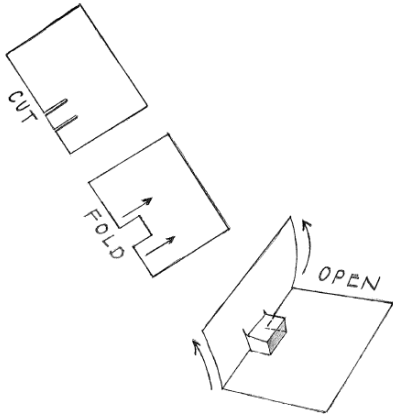

Pop-up books are simple, yet complex spatial illusions that are fun and relatively easy to create. The basic concept of the pop-up is diagramed at left. Practice making this basic unit by folding a piece of scratch paper in half. On the folded edge, cut two parallel slits into the paper to create a tab. (Score your lines with pencil and a ruler, if you need help.) Invert the tab by folding it down and loosening it. Open the paper like a book and push the tab in with your finger so that the tab "pops up" from the center fold. Manipulate this basic unit to create more complex shapes by testing out some of the following techniques:

- Cut deeper into the folded edge or make more shallow cuts to create shapes of differing depths. Be careful not to cut too deep so as not to weaken the form.
- Use push-pins to invert the "pop-up" tab with precision.
- Play with positive and negative space by cutting shapes out of the tab. Think of the tab as positive space and the shapes that you cut out as negative space.
- Hole-punch the tab to create patterns and shapes.
- Decorate the edge of the tab with colored pencils or decorative paper to add color and design.
- Save and repurpose your scraps.

Now that you have tested out various techniques, choose a motif, or theme, for your pop-up book. Use language arts vocabulary words to create a word association game, a literary device popular with surrealists and their fascination with unveiling the subconscious. For instance, use terms from a lesson on the ecosystem, such as savanna, desert, tundra, and forest to draft a list of related colors (warm versus cool), shapes (organic versus geometric), textures (smooth, rough, sandy), etc. Use these words as inspiration for creating your pop-up cover!

When finished, create a simple book by folding a piece of cardstock as book cover, inserting folded copy paper as book pages, and staple on the folded edge as binding. The dimensions of the book should match the dimensions of the pop-up card. Attach your pop-up card to the cover of the book with glue or tape.

Reflection

Many surrealists, including Lundeberg, incorporated writing into their practice. This often took the form of automatism, or automatic writing and drawing. Automatism to the artist is what improvisation is to the jazz musician – the spontaneous and uncontrolled creation of images and/or words, straight from the artist's imagination to the page.

Use your book to practice automatism techniques, to create an exquisite corpse drawing with a friend (another popular surrealist game), or as a place to brainstorm ideas for classroom writing prompts.

Surrealism and Women Artists

Selected Resources

Related Curriculum Materials

Evenings for Educators resources include an illustrated essay, color images or overhead transparencies, classroom activities, and related resources. Printed curriculum is available for purchase through LACMA's Education Department or browse selected curricula online at www.lacma.org (Programs /Education/Evenings for Educators).

Artists' Perspectives: Envisioning the World
April 2009

Dali and Surrealism
December 2007

Image and Text: Magritte and his Impact
February 2007

Mirror Image to Masquerade: Photographic Portraits
November 2006

Online Resources

"Surrealism" on the Heilbrunn Timeline of Art History

The Metropolitan Museum of Art

http://www.metmuseum.org/toah/hd/surr/hd_surr.htm

Learn more about the movement in the context of art history through interactive timelines, thematic essays, maps, and images.

Surrealist Art

Centre Pompidou

<http://www.cnac-gp.fr/education/ressources/ENS-Surrealistart-EN/ENS-Surrealistart-EN.htm>

Explore the origins of surrealism, important surrealist artists, and iconic works.

Teacher's Guide to *The Life and Times of Frida Kahlo*

Public Broadcasting Service (PBS)

http://www.pbs.org/weta/fridakahlo/guides/teachers_guide.pdf

An educational accompaniment to this intimate biography of Kahlo, including standards-based lesson plans and discussion questions.

Louise Bourgeois on *Art21*

Public Broadcasting Service (PBS)

<http://www.pbs.org/art21/artists/louise-bourgeois>

Documentation of the late Bourgeois' life and work from *Art21*, the television series and chronicler of contemporary art and artists.

Feminist Art Base

Brooklyn Museum

http://www.brooklynmuseum.org/easca/feminist_art_base/index.php

The first online digital archive dedicated solely to feminist art, created by the Elizabeth A. Sackler Center for Feminist Art at the Brooklyn Museum.

Educator's Guide for *Lauren Greenfield's Girl Culture*

Center for Creative Photography at the University of Arizona Libraries

<http://www.creativephotography.org/education/educatorsGuides>

A selection of photographs and first-person narratives from the Center for Creative Photography's 2002 exhibition, which examined the social and emotional lives of adolescent girls and their relationships to contemporary media and conceptions of beauty.

Books for Teachers

- Bernhard, Ruth. *Ruth Bernhard: The Eternal Body*. San Francisco: Chronicle Books, 2011. A monograph of Bernhard's most celebrated photographs of the female form.
- Chadwick, Whitney. *Women Artists and the Surrealist Movement*. London: Thames & Hudson, 1991. A comprehensive review of the lives and works of women who shaped the Surrealist movement.
- Coxon, Ann. *Tate Modern Artists: Louise Bourgeois*. London: Tate Publishing, 2010. A survey of Bourgeois' experimentation with a plethora of media and techniques, from painting and assemblage to sculpture, paper, and beyond. Quotations and interviews with the artist provide insight into her artistic process.
- Ferrer, Elizabeth. *Lola Alvarez Bravo*. Tuscon: Aperture/Center for Creative Photography, 2006. The first English-language monograph documenting the Mexican photographer's career, including previously unpublished works, little-known photomontages, and portraits of friend, Frida Kahlo.
- Fort, Ilene Susan, Tere Arcq, and Terri Geis. *In Wonderland: The Surrealist Adventures of Women Artists in Mexico and the United States*. New York: Prestel Publishing, 2012. Catalogue for the LACMA exhibition, featuring the work of 48 Mexican and United States-based women artists whose contributions to the surrealist movement span more than four decades.*
- Rapaport, Brooke Kamin (Ed.). *The Sculpture of Louise Nevelson: Constructing a Legend*. New Haven: Yale University Press, 2009. The most extensive study of Nevelson's work, from her origins as a Ukrainian-born Jewish immigrant to the United States, to her groundbreaking works of the 1940s, her influence on the public art revival of the 1960s, and her complex architectural works from the 1980s.

Books for Students

- Alarcon, Francisco X. *Poems to Dream Together/Poemas para Sonar Juntos*. New York: Lee & Low Books, 2005. A bilingual collection of short poems about the power of dreams.
- Novesky, Amy. *Me, Frida*. New York: Abrams Books for Young Readers, 2010. An account of Kahlo's move to San Francisco with husband Diego Rivera, her first time leaving Mexico, and her search for artistic inspiration.*
- Raimondo, Joyce. *Imagine That!: Activities and Adventures in Surrealism*. New York: Watson-Guptill, 2004. An introduction to surrealism highlighting the work of six famous surrealists. Includes easy-to-follow activities on techniques and media such as collage, watercolors, printmaking, sculpture, and more.
- Ryan, Pam Munoz. *The Dreamer*. New York: Scholastic Press, 2010. The story of a young boy, Neftalí, who follows the call of a mysterious voice into the fearsome sea, under the canopy of the lush rain forest, and through the persistent Chilean rain. A combination of magical realism with poetry and illustrations.

* Books available in the Museum Shop